



Features

- Panel Loading Stations are available in five pressure ranges
- High flow capacity suitable for most control operations
- Automatic relief allows station to be left unattended
- Precision regulator satisfies most industrial requirements

Operating Principles

Models PL-5 and PLT-8 Panel Loading Stations maintain and monitor output pressure for pneumatic instrumentation.

The PL-5 includes a regulator (Model 10, Model 30, Model 64/65A, or Model 81) and a standard pressure gage that allows operator to set and read pressure at the panel.

The PLT-8 includes a regulator (Model 10, Model 30, or Model 64A/65A) and a three-way valve that allows operator to monitor the process in manual or automatic mode. In manual mode, operator can set and read the pressure at the panel. In automatic mode, operator can set the pressure from a remote location and read the pressure at the panel.

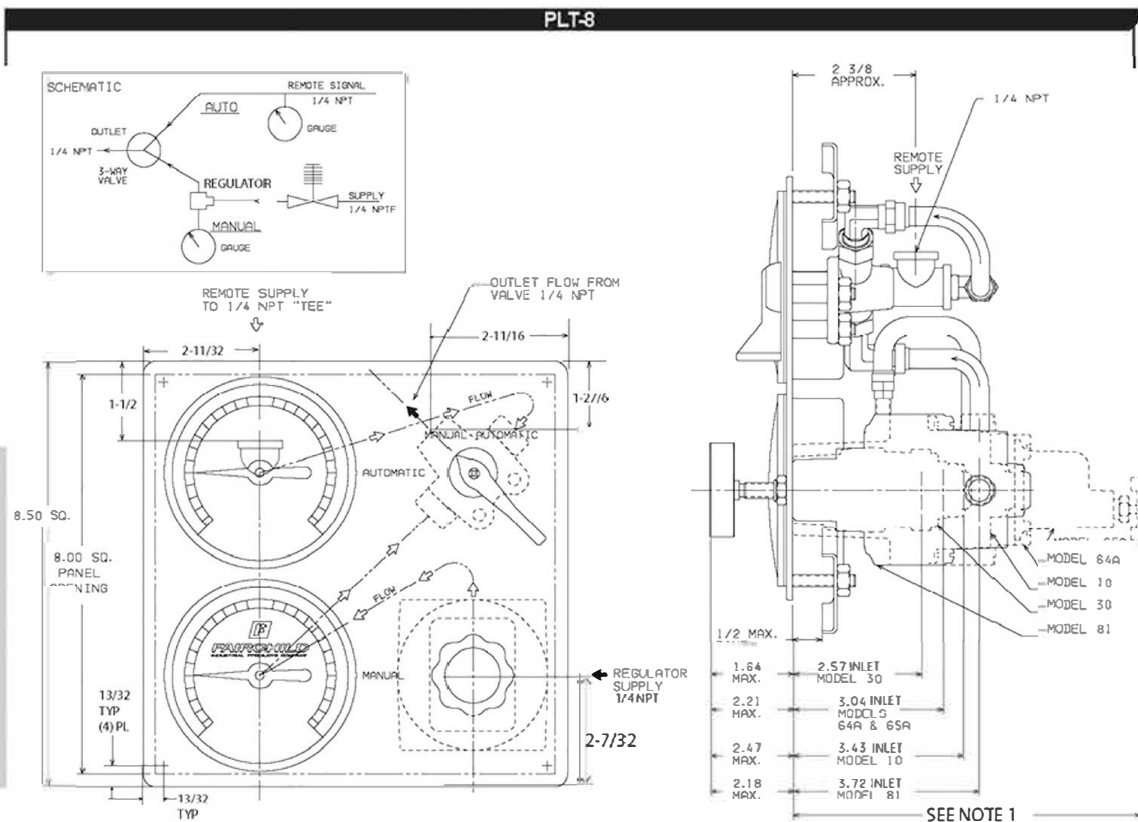
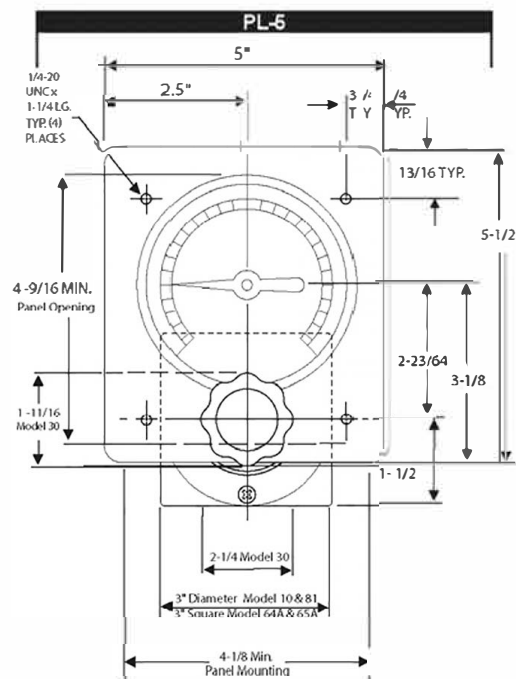

Note 1

Depth from panel depends on regulator used:

- Model 10 - 4-13/16" (122.2 mm)
- Model 30 - 3-13/16" (96.8 mm)
- Model 64A - 5-3/32" (129.4 mm)
- Model 65A - 7-13/32" (188.1 mm)
- Model 81 - 4-3/4" (120.7 mm)

Models
PL-5
PLT-8

Models PL-5, PLT-8 Panel Loading Stations

Specifications

Gage Accuracy

Lower Third.....	± 3%
Mid Scale.....	± 2%
Upper Third.....	± 3%

Model NO.	psig	Range [BAR]	(kPa)	Flow SCFM (m³/HR)	Sensitivity W.C. cm
10	0-20	[0-1.5]	(0-150)	40 (68)	0.125 .31
	.5-30	[0.03-2.0]	(3.0-200)		
	1-60	[0.1-4.0]	(10-400)		
	2-150	[0.15-10.0]	(15-1000)		
30	.5-30	[0.03-2.0]	(3.0-200)	30 (51)	0.250 .63
	1-60	[0.1-4.0]	(10-400)		
	2-100	[0.15-7.0]	(15-700)		
64A	.5-30	[0.03-2.0]	(3.0-200)	22 (37.4)	1.0 2.54
	1-60	[0.1-4.0]	(10-400)		
	2-200	[0.15-14.0]	(15-1400)		
65A	.5-30	[0.03-2.0]	(3.0-200)	22 (37.4)	1.0 2.54
	1-60	[0.1-4.0]	(10-400)		
	2-100	[0.15-7.0]	(15-700)		
81	0-20	[0-1.5]	(0-150)	50 (85)	less than .25
	.5-60	[0.03-4.0]	(3.0-400)		
	.5-100	[0.03-7.0]	(3.0-700)		

Ambient Temperature

10, 30, 81.....	-40°F to 200°F (-40°C to 93.2°C)
64A, 65A.....	-40°F to 180°F (-40°C to 82.2°C)

Models
PL-5
PLT-8

Model	Panel Opening* (Width by Height)	
PL5	4-1/8" x 4-9/16"	105 mm x 116 mm
PLT8	8" x 8"	203 mm x 203 mm

* All Dimensions + 1/8", -0 (+.3 mm - 0) PL5 fits ISA RPC Cutouts

"A & B" Inlet and Outlet connections are 1/4" NPT

Catalog Information

Catalog Number

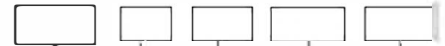

Panel

with Transfer Function ...

PLT8

without Transfer Function.

PL5

Regulator

Model 10.....	10
Model 30.....	30
Model 64A.....	64
Model 65A.....	65
Model 81.....	81

Gage Type

Single Plain.....	P
Dual Plain (PLT8 Only).....	DP
Single Receiver ¹ (Graduated 0-100%).....	R
Dual Receiver (PLT8 Only).....	DR

Regulator Range ²

psig	[BAR]	(kPa)	
20 ³	[1.5]	(150)	20
30 ⁴	[2.0]	(200)	30
60 ⁵	[4.0]	(400)	60
100 ⁶	[7.0]	(700)	100
150 ⁷	[10.0]	(1000)	150

Gage Range

psig	[BAR]	(kPa)	
15	[1.0]	(100)	15
30	[2.0]	(200)	30
60	[4.0]	(400)	60
100	[7.0]	(700)	100
160	[11.0]	(1100)	160

¹ 0-100% scale for 3-15 psig, [0.2-1.0 BAR], (20-100 kPa) range.

² To avoid gage damage, the regulator range should be equal to or less than the gage range.

³ For Models 10 & 81 Only.

⁴ For Models 10, 30, 64A, & 65A Only.

⁵ For Models 10, 30, 64A, 65A, & 81.

⁶ For Models 30, 64A, 65A, & 81.

⁷ For Model 10 Only.

Service Information

For installation instructions, refer to the *Model PL-5, PLT-8 Panel Loading Stations Installation, Operation, and Maintenance Instructions*, IS-4PL5PLT8. For more information, refer to the *Installation, Operation, and Maintenance Instructions* for the appropriate Regulator:

- Model 10 - IS-10000010
- Model 30 - IS-10000030
- Model 64A,65A - IS-1064A65A
- Model 81 (PL-5 only) - IS-10000081